

## RI-D140 Series

### Three Phase Multifunction DIN Rail Energy Meter (MID Certified)



- Four module DIN rail mounted
- Energy pulse LED
- -/1A or -/5A current transformer input (MID certification only on 5A)
- Single phase or three phase network compatible
- Programmable voltage and current transformer ratio
- True RMS measurement
- MID B+D Certified (SGS Cert. No. : 0120/SGS0276)
- High definition white backlit LCD display
- Simple programming and operation
- Modbus communication
- Auto and manual page scrolling

#### Product Description

The RI-D140 is a MID approved DIN rail mounted multifunction energy meter. Suitable for monitoring energy consumption and many other electrical parameters in industrial and commercial applications. These meters may be used in single or three phase four wire systems.

A high efficiency white backlit LCD display provides a clear indication of the measured value in all light conditions. Push-buttons on the front of the meter allow the user access to the display page required.

Its MID status means the RI-D140 has been tested for the build quality and accuracy of the meter and is certified for billing purposes.

The meter is currently available in one version:

- With RS485 Modbus communication.  
(Mbus version coming soon)

The unit is housed in a compact four module width housing suitable for 35mm DIN rail mounting.

#### Displayed Parameters

**Voltage – L-L, L-N and average**

**Current – Per phase and average**

**Power Factor – per phase and average**

**Frequency**

**Power – Active, Reactive and Apparent (per phase and total)**

**Power Min./Max. demand – Active and apparent power.**

**Energy – Active, reactive and apparent (per phase and total)**

**Import and export energy – Active, Reactive and Apparent (per phase and total)**



## Display

Display Type	LCD, High definition with white back-light	
Digit height	6.35mm (Displayed parameter)	
Page scrolling	Manual by front key / or auto scroll mode	
Displayed parameters and accuracies	Voltage	0.5% of full scale
	Current	0.5% of full scale
	Frequency	0.1% of full scale (L-N >20V)
	Power factor	1% of unity
	Active power	1%
	Reactive power	1%
	Apparent power	1%
	Active Energy	Class 1, Class B (IEC/EN62053-21, IEC/EN50470-3)
	Reactive Energy	Class 2 (IEC/EN62053-23)
Energy maximum display	9999999	
Resolution	0.01K, 0.1K, 1K, 0.01M, 0.1M, 1M (depending on CT ratio & VT ratio)	

## Programming

Parameters that can be changed using programming menu	<b>CT Primary current</b> <b>CT Secondary current</b> <b>VT primary voltage</b> <b>VT secondary voltage</b> Communication address Communication speed (Baud) Communication Parity Communication number of stop bits Back-light time-out period Demand period (for integration) <b>Reset to Factory Default</b> <b>Reset Energy and Maximum Demand</b> <b>Reset Active Energy</b> <b>Reset Reactive Energy</b> <b>Reset Apparent Energy</b> Reset Maximum Current Reset Maximum Active Power Reset Minimum Active Power Reset Maximum Reactive Power Reset Minimum Reactive Power Reset Maximum Apparent Power
<i><b>NOTE: Once Programming Mode Is entered The values in red will be locked out after 15 Mins. No further adjustment is possible without return to factory.</b></i>	
Programming access	Password protected (user selectable)
Memory retention	Non volatile memory

## Input

Connection	Single phase (CT on L1 only), Three phase four wire
Certified voltage range	85...240V (L - N), 147...415 (L - L)
Voltage rated burden	<0.2VA
Nominal current input	0.05...5A
Max current (Imax)	6A (1.2 x Nominal)
Current Rated Burden	0.5VA
Starting current	10mA
Short time overcurrent	30 x Imax to IEC/EN62053-21 + 23
Impulse voltage withstand	6kV 1.2/50µS 0.5J
AC voltage withstand	4kV 50Hz for 1 min.
CT primary current	5...6000A
VT primary voltage	100...600V
Frequency	50Hz
Current distortion factor	According to IEC/EN50470

## Auxiliary Supply

Voltage range	100...240V (±15%)
Operating frequency	47...65Hz
Power consumption	<8VA

## Outputs

Communication - Modbus	
Communication type	RS485
Communication protocol	Modbus
Address	1...255
Number of bits	8bits
Parity	None, odd, even
Baud rate	300, 600, 1200, 2400, 4800, 9600, 19200
Required response time to request	≤100ms
Number of meters connected on the bus	32 (up to 255 with RS485 repeater)
Max distance from Master device	500M

## Insulation

Installation category	III
Pollution degree	2
Insulation voltage rating	300V (L-N)

## Environmental Conditions

Reference temperature	23°C ±2°C
Specified temperature operating range	-10°C...+55°C
Storage temperature	-20°C...+75°C
Relative humidity	0...85%, non condensing
Mechanical environment	M1
Electromagnetic environment	E2

## Mechanical

Housing	
Housing	4 module DIN 43880
Mounting	Snap-on 35mm rail
Tamper sealing	Meter housing (by means of a tamper evident seal). Sealable terminal covers.
Housing material	Self-extinguishing polycarbonate (UL94 V-0)
Protection degree (IEC/EN60529)	IP20 (terminals), IP51 (front of housing)
Weight	<210g
Termination	
Current input terminal type	Screw clamp type
Max wire size	4.0mm <sup>2</sup>
Voltage input terminal type	Screw clamp type
Max wire size	4.0mm <sup>2</sup>
Output terminal type	Screw clamp type
Max wire size	2.5mm <sup>2</sup>

## Conformity

Electromagnetic compatibility	IEC/EN61326-1, IEC/EN55011 Class A, IEC/EN61000-4-2, -3, -4, -5, -6, -8, -11 IEC/EN50470-1/3
Accuracy and functionality	IEC/EN50470-1/3, IEC/EN62053-21, IEC/EN62053-23, DIRECTIVE 2014/32/EU
Safety	IEC/EN61010, IEC/EN50470-1

**Wiring Diagrams**

**Note:** # All fuse types : 0.5A class CC UL type  
0.5A fast acting 600V

**3 Phase 4 Wire - 3 CTs**

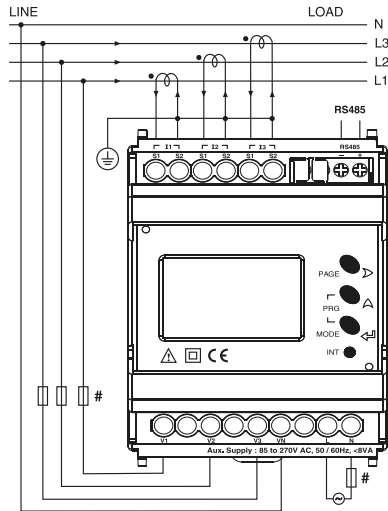

**3 Phase 4 Wire - 3 CTs and 3 PTs**

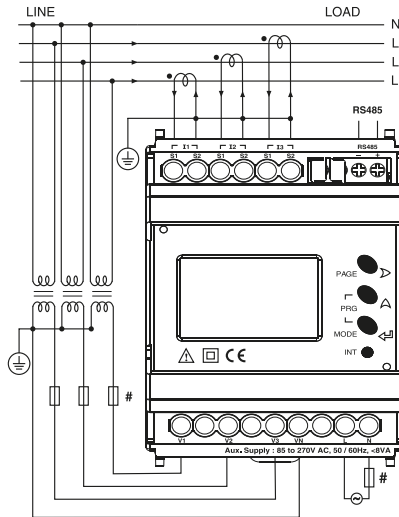

**Single Phase 2 Wire - 1 CTs**

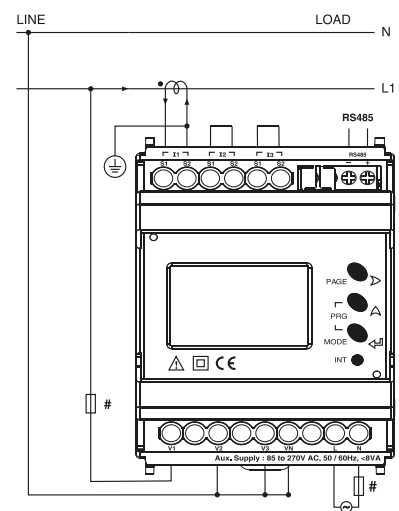

**Dimensions (mm)**

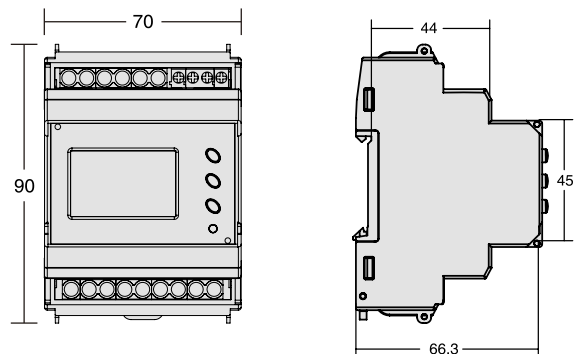

**Model Selection Table**

Communications	Model
RS485 Modbus output	RI-D140-G-C
Mbus and pulse output	Coming Soon